

PennEngineering®

SELF-CLINCHING TY-D® CABLE  
TIE-MOUNTS AND HOOKS





BULLETIN **TD**



# SELF-CLINCHING TY-D® CABLE TIE-MOUNTS AND HOOKS

PEM® TY-D® self-clinching tie-mounts and hooks provide secure attachment points for mounting wires to electronic chassis or enclosures. All TY-D hardware installs quickly and permanently without screws and eliminates the use of adhesives that typically fail over time and temperature cycling.

TY-D hardware can be a great improvement over traditional mounting methods. They can be placed with assurance at designed locations and angles to remain secure for the life of the assembly; they will not protrude on the reverse side and will not affect the reverse side appearance or clearance; and panels remain flush, minimizing EMI/RFI and contamination of electronics by dust or dirt.

<p><b>Type TD™ mounts</b> allow users to easily slide ties through the hardware's "eye" for fast cable mounting.</p>	 A top-down diagram of a Type TD mount. It features a central rectangular opening (the "eye") with a raised rim. Two mounting tabs extend horizontally from the base of the central opening.
<p><b>Type TDO™ hooks*</b> enable users to attach, remove, and return tie-bundled wires to their mounting points when components need to be accessed for service or when wires must be replaced. The hook feature allows ties to remain intact and wires to remain wrapped.</p>	 A top-down diagram of a Type TDO hook. It has a large, open C-shaped hook at the top. Below the hook is a rectangular base with two mounting tabs extending horizontally from its bottom edge.

\*Patented.



Reverse side of Type TDO installed in sheet.



Type TDO open end orientation mark.

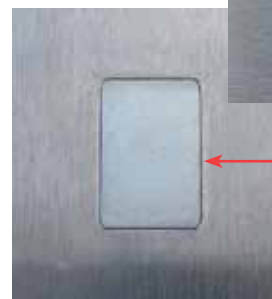

Reverse side of Type TD installed in sheet.

Depending on placement of the fastener within the mounting hole, a slight gap may be noticeable along the non-clinching edges of the fastener after installation.

# SELF-CLINCHING TY-D® CABLE TIE-MOUNTS AND HOOKS

## TYPE TD™ CABLE TIE-MOUNTS

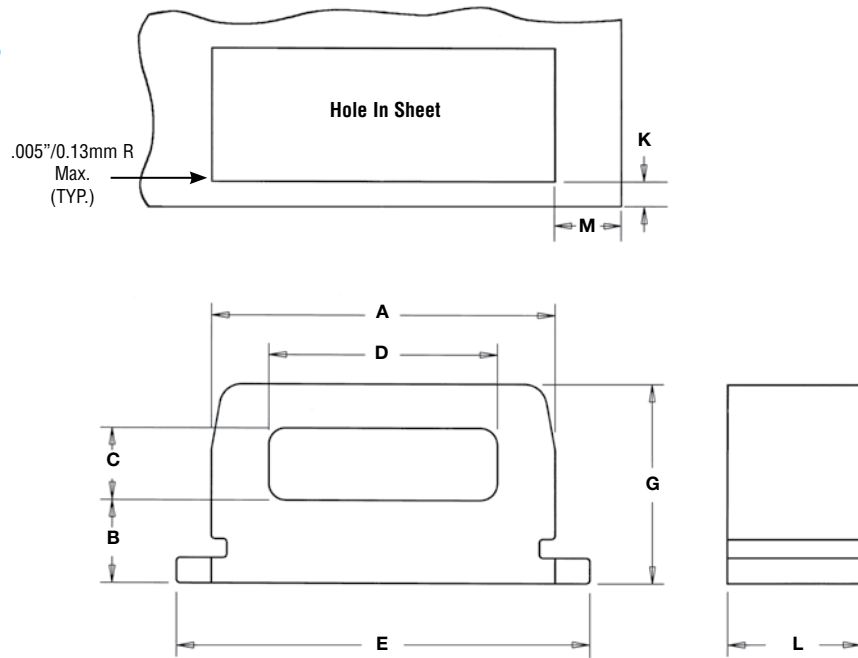

All dimensions are in inches.

UNIFIED	Type	Profile (1)	Length Code	Length L ±.003	Sheet Thickness	Hole Size In Sheet +.002 -.001	A ±.003	B ±.006	C ±.006	D ±.006	E ±.006	Height G ±.006	Min. Hole Edge To Sheet Edge K	Min. Hole Edge To Sheet Edge M
	TD	40	4	.121	.040 - .050	.250 x .125	.246	.055	.065	.160	.308	.150	.040	.147
	TD	60	6	.184	.040 - .070	.312 x .187	.308	.075	.065	.205	.370	.180	.040	.196
	TD	175	12	.371	.040 - .125	.500 x .375	.496	.130	.095	.360	.562	.285	.040	.262

All dimensions are in millimeters.

METRIC	Type	Profile (1)	Length Code	Length L ±0.08	Sheet Thickness	Hole Size In Sheet +0.05 -0.03	A ±0.08	B ±0.15	C ±0.15	D ±0.15	E ±0.15	Height G ±0.15	Min. Hole Edge To Sheet Edge K	Min. Hole Edge To Sheet Edge M
	TD	40	4	3.07	1.02 - 1.27	6.35 x 3.18	6.25	1.4	1.65	4.06	7.82	3.81	1.02	3.73
	TD	60	6	4.67	1.02 - 1.78	7.93 x 4.75	7.82	1.91	1.65	5.21	9.4	4.57	1.02	4.98
	TD	175	12	9.42	1.02 - 3.18	12.7 x 9.53	12.6	3.3	2.4	9.14	14.28	7.24	1.02	6.65

(1) Reference to typical load rating (in pounds) for appropriate size nylon cable tie.

### PART NUMBER DESIGNATION

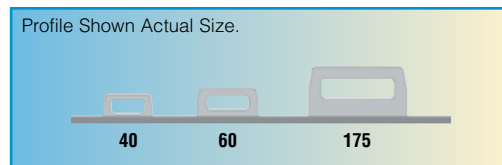
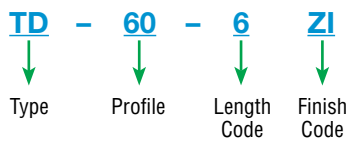

# SELF-CLINCHING TY-D® CABLE TIE-MOUNTS AND HOOKS

## TYPE TDO™ CABLE TIE HOOKS

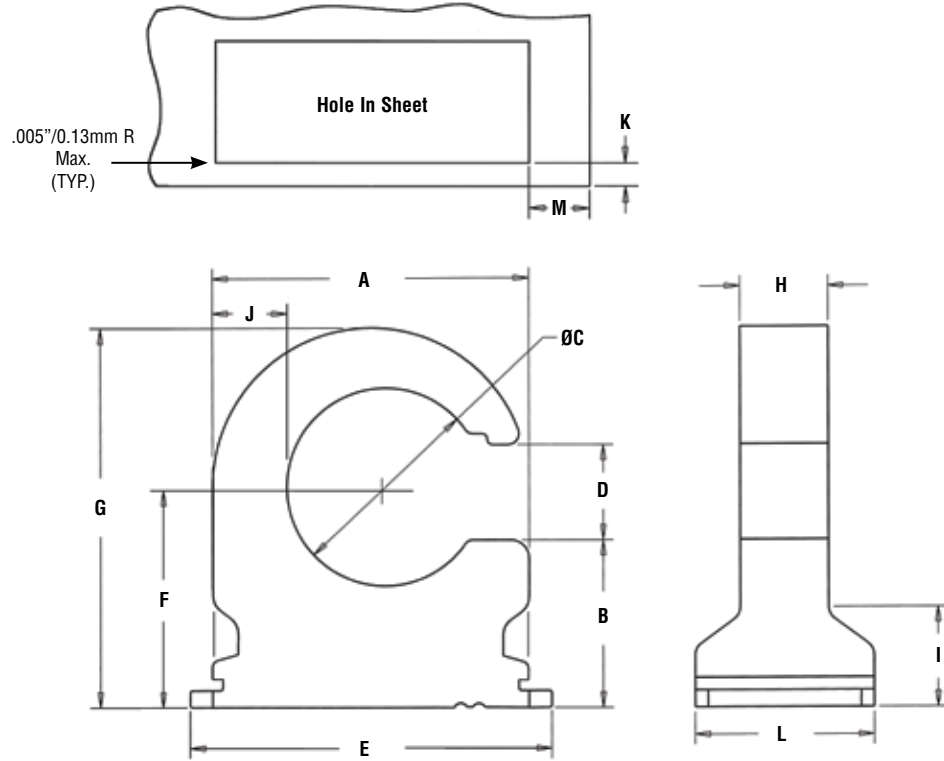

All dimensions are in inches.

UNIFIED	Type	Profile (1)	Length Code	Length L ±.003	Sheet Thickness	Hole Size In Sheet +.002 -.001	A ±.003	B ±.006	ØC ±.006	D ±.006	E ±.006	F ±.005	Height G Nom.	H ±.010	I ±.010	J Nom.	Min. Hole Edge To Sheet Edge K	Min. Hole Edge To Sheet Edge M
	TDO	40	8	.246	.040 - .155	.250 x .375	.371	.213	.245	.130	.433	.285	.471	.12	.13	.083	.040	.147
	TDO	50	8	.246	.040 - .155	.250 x .438	.434	.228	.270	.130	.496	.300	.517	.12	.13	.102	.040	.196
	TDO	120	8	.246	.040 - .155	.250 x .562	.558	.255	.340	.140	.620	.335	.614	.12	.13	.139	.040	.262

All dimensions are in millimeters.

METRIC	Type	Profile (1)	Length Code	Length L ±0.08	Sheet Thickness	Hole Size In Sheet +0.05 -0.03	A ±0.08	B ±0.15	ØC ±0.15	D ±0.15	E ±0.15	F ±0.13	Height G Nom.	H ± 0.25	I ± 0.25	J Nom.	Min. Hole Edge To Sheet Edge K	Min. Hole Edge To Sheet Edge M
	TDO	40	8	6.25	1.02 - 3.94	6.35 x 9.53	9.42	5.41	6.22	3.3	11	7.24	11.96	3.05	3.3	2.11	1.02	3.73
	TDO	50	8	6.25	1.02 - 3.94	6.35 x 11.13	11.02	5.79	6.86	3.3	12.6	7.62	13.13	3.05	3.3	2.59	1.02	4.98
	TDO	120	8	6.25	1.02 - 3.94	6.35 x 14.27	14.17	6.48	8.64	3.56	15.75	8.51	15.6	3.05	3.3	3.53	1.02	6.65

(1) Reference to typical load rating (in pounds) for appropriate size nylon cable tie.

### PART NUMBER DESIGNATION

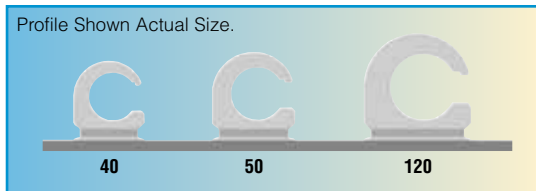
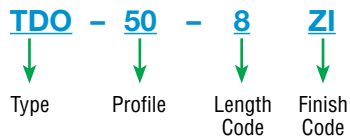

Type TDO  
open end  
orientation  
mark.



# SELF-CLINCHING TY-D® CABLE TIE-MOUNTS AND HOOKS

## MATERIAL AND FINISH SPECIFICATIONS

**MATERIAL:** Sintered Steel

**FINISH:** ZI- Zinc plated, 5µm, colorless <sup>(1)</sup>

**FOR USE IN SHEET HARDNESS:** HRB 60 / HB 107 or less <sup>(2)</sup>

(1) See PEM Technical Support section of our web site for related plating standards and specifications.

(2) HRB - Hardness Rockwell "B" Scale. HB - Hardness Brinell.

## PERFORMANCE DATA<sup>(3)</sup>

### TYPE TD

UNIFIED	Part Number	Test Sheet Material							
		Cold-rolled Steel				5052-H34 Aluminum			
		Installation (lbs.)	Pushout (lbs.)	Pull Thru (lbs.)	Side Load (lbs.)	Installation (lbs.)	Pushout (lbs.)	Pull Thru (lbs.)	Side Load (lbs.)
	TD-40-4	1800	175	100	90	1000	90	100	90
	TD-60-6	2500	260	160	100	1500	140	160	100
	TD-175-12	4000	350	175	140	3000	235	175	140

METRIC	Part Number	Test Sheet Material							
		Cold-rolled Steel				5052-H34 Aluminum			
		Installation (kN)	Pushout (N)	Pull Thru (N)	Side Load (N)	Installation (kN)	Pushout (N)	Pull Thru (N)	Side Load (N)
	TD-40-4	8	780	445	400	4.5	400	445	400
	TD-60-6	11	1160	712	445	6.7	620	712	445
	TD-175-12	17.7	1560	780	620	13.3	1040	780	620

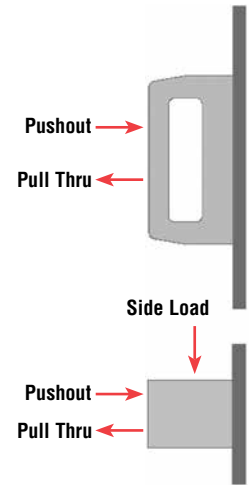

### TYPE TDO

UNIFIED	Part Number	Cable Tie Screw Size	Test Sheet Material							
			Cold-rolled Steel				5052-H34 Aluminum			
			Installation (lbs.)	Pushout (lbs.)	Pull Thru (lbs.)	Hanging Load (lbs.)	Installation (lbs.)	Pushout (lbs.)	Pull Thru (lbs.)	Hanging Load (lbs.)
	TDO-40-8	#8	3000	105	70	145	2000	105	70	130
	TDO-50-8	#10	3000	150	90	145	2000	130	90	130
	TDO-120-8	1/4	3000	200	110	145	2000	145	110	130

METRIC	Part Number	Cable Tie Screw Size	Test Sheet Material							
			Cold-rolled Steel				5052-H34 Aluminum			
			Installation (kN)	Pushout (N)	Pull Thru (N)	Hanging Load (N)	Installation (kN)	Pushout (N)	Pull Thru (N)	Hanging Load (N)
	TDO-40-8	M4	13.4	465	310	645	8.9	465	310	575
	TDO-50-8	M5	13.4	665	400	645	8.9	575	400	575
	TDO-120-8	M6	13.4	890	490	645	8.9	645	490	575

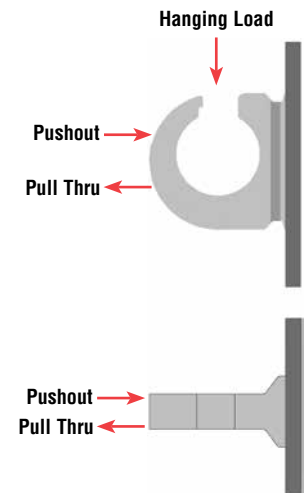

(3) The values reported are averages when all installation specifications and procedures are followed. Variations in mounting hole size will affect results. Performance testing of this product in your application is recommended. We will be happy to provide samples for this purpose.

# SELF-CLINCHING TY-D® CABLE TIE-MOUNTS AND HOOKS

## INSTALLATION

1. Punch a properly sized rectangular mounting hole in the sheet. Do not perform any secondary operations such as deburring.
2. Place the fastener through the mounting hole (preferably the punch side) and into the anvil.
3. With the installation punch and anvil surfaces parallel, apply a squeezing force until the bottom of the fastener becomes flush with the sheet.

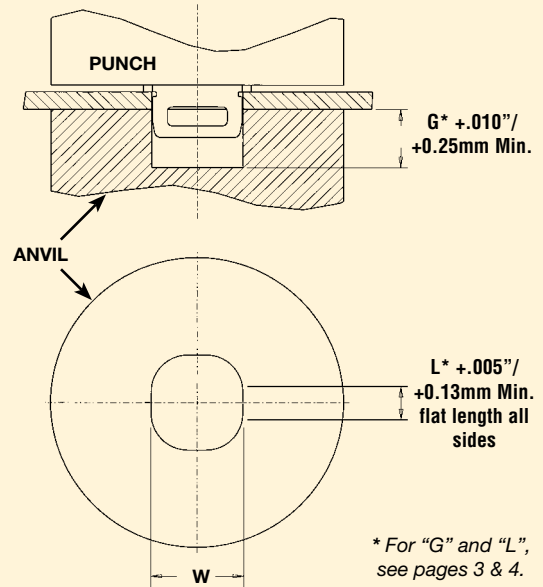

## PEMSERTER® Installation Tooling

All dimensions are in inches.

UNIFIED	Part Number	W ±.001	Anvil Part Number	Punch Part Number
	TD-40-4	.251	8006136	8003076
	TD-60-6	.313	8006137	
	TD-175-12	.501	8006138	
	TDO-40-8	.379	8006865	
	TDO-50-8	.442	8006864	
	TDO-120-8	.566	8006863	

All dimensions are in millimeters.

METRIC	Part Number	W ±0.03	Anvil Part Number	Punch Part Number
	TD-40-4	6.36	8006136	8003076
	TD-60-6	7.95	8006137	
	TD-175-12	12.73	8006138	
	TDO-40-8	9.63	8006865	
	TDO-50-8	11.23	8006864	
	TDO-120-8	14.38	8006863	

**NOTE:** The punch must be large enough to cover the entire base of the fastener to ensure proper installation.

### PEMSERTER® PRESSES

For best results we recommend using a PEMSERTER® press for either manual or automatic installation of PEM TY-D hardware. For more information on our line of presses check our website.

Regulatory compliance information is available in Technical Support section of our website. © 2013 PennEngineering.

Specifications subject to change without notice. Check our website for the most current version of this bulletin.

**PennEngineering®**



**North America:** Danboro, PA USA • E-mail: [info@pemnet.com](mailto:info@pemnet.com) • Tel: +1-215-766-8853 • Fax: +1-215-766-0143 • 800-237-4736 (USA Only)  
**Europe:** Galway, Ireland • E-mail: [europe@pemnet.com](mailto:europe@pemnet.com) • Tel: +353-91-751714 • Fax: +353-91-753541  
**Asia/Pacific:** Singapore • E-mail: [singapore@pemnet.com](mailto:singapore@pemnet.com) • Tel: +65-6-745-0660 • Fax: +65-6-745-2400  
 Shanghai, China • E-mail: [china@pemnet.com](mailto:china@pemnet.com) • Tel: +86-21-5868-3688 • Fax: +86-21-5868-3988

Visit our PEMNET™ Resource Center at [www.pemnet.com](http://www.pemnet.com)

Technical support e-mail: [techsupport@pemnet.com](mailto:techsupport@pemnet.com)