

# PennEngineering®

SI® THREADED INSERTS FOR PLASTICS



BULLETIN

# SI



# SI® THREADED INSERTS FOR PLASTICS

- SI inserts are typically specified in applications where strong, durable metal threads are required in plastic material, especially where frequent assembly and disassembly of the unit for service or repair is necessary.
- Applications for SI® products include: computers and terminal boards, automotive, electronic equipment, business machines, aerospace, communications equipment and instrument cases.
- SI inserts are available in brass, stainless steel and aluminum.
- SI inserts are available in a large variety of ultrasonic / heat staking, molded-in or press-in types.
- SI inserts meet the strictest quality guidelines which are maintained through in-process audits.

## ULTRASONIC / HEAT STAKING INSERTS

- Ultrasonic - Installed by pressing the insert into the mounting hole with ultrasonic insertion equipment while simultaneously applying a high frequency vibration. Frictional heat caused by the vibration melts the plastic surrounding the insert allowing easy insertion. When the vibration ceases, the plastic solidifies, locking the insert permanently in place.
- Heat Staking - Installed by pressing the insert into the mounting hole with a thermal press to melt the plastic surrounding the insert.

## MOLDED-IN INSERTS

- Installed during the molding process, the inserts are located in the mold cavity by core pins. When the mold opens, the core pins are withdrawn leaving the inserts permanently encapsulated in the plastic section with only the threads exposed.
- Installing the inserts during the molding process eliminates the need for secondary steps or installation equipment.

## PRESS-IN INSERTS

- Installed by simply pressing the inserts into pre-molded or drilled holes. Installation is accomplished using any standard press at any time during the production process.
- Eliminates the need for molding-in inserts.
- Eliminates the need for heat or ultrasonic equipment.



# TABLE OF CONTENTS

## ULTRASONIC / HEAT STAKING THREADED INSERTS

IUB, IUC (Tapered, thru-threaded inserts) . . . . .	<b>SI-4</b>
IUTB, IUTC (Straight wall, thru-threaded inserts) . . . . .	<b>SI-5</b>
ISB, ISC (Symmetrical, thru-threaded inserts). . . . .	<b>SI-6</b>
Performance data for ultrasonic inserts . . . . .	<b>SI-7</b>

## MOLDED-IN THREADED INSERTS

IBB, IBC (Blind threaded inserts) . . . . .	<b>SI-8</b>
IBLC (Self-locking blind threaded inserts) . . . . .	<b>SI-9</b>
ITB, ITC (Thru-threaded inserts) . . . . .	<b>SI-10</b>
STKB, STKC (Knurled spacers). . . . .	<b>SI-11</b>
Performance data for molded-in inserts . . . . .	<b>SI-12</b>

## PRESS-IN THREADED INSERTS

NFPC, NFPA (Hexagonal, press-in inserts). . . . .	<b>SI-13</b>
PPB (Thru-threaded inserts) . . . . .	<b>SI-14</b>
PFLB (Flange-head inserts). . . . .	<b>SI-15</b>
PKB (Straight knurl inserts) . . . . .	<b>SI-16</b>
Performance data for press-in inserts. . . . .	<b>SI-17</b>

SI Custom Designs. . . . .	<b>SI-18</b>
Hole Preparation Guidelines . . . . .	<b>SI-19</b>
SI Prototype Kit. . . . .	<b>SI-20</b>

## PART NUMBER DESIGNATION AND MATERIAL AND FINISH SPECIFICATIONS

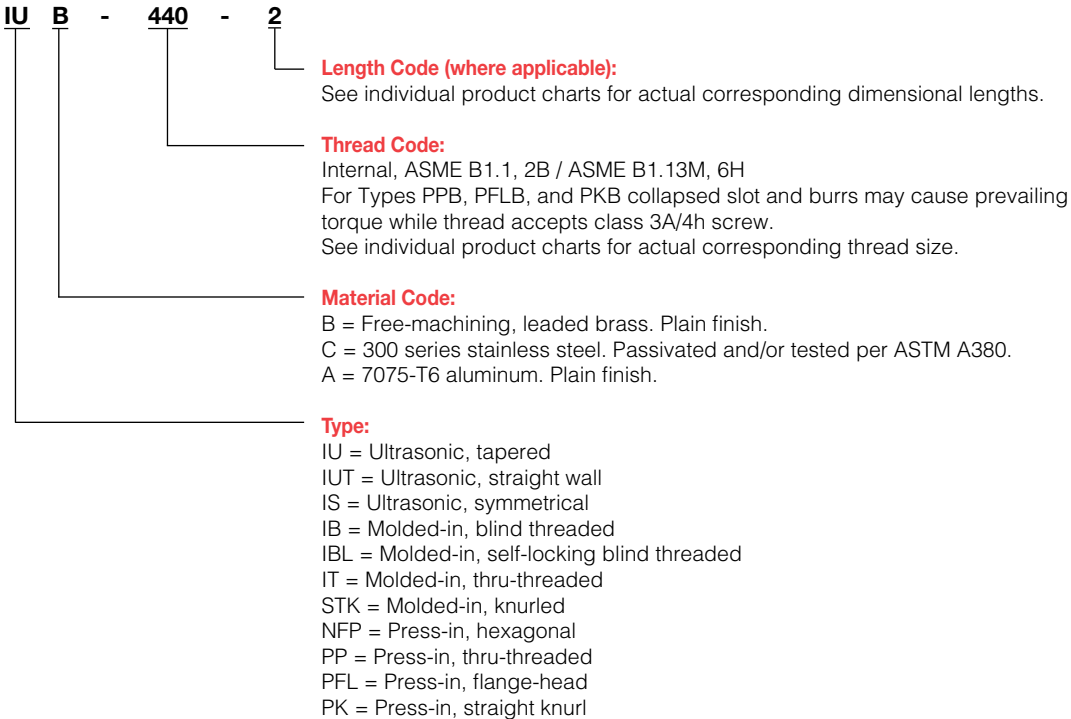

# ULTRASONIC / HEAT STAKING INSERTS

## Tapered Thru-Threaded, Types IUB™ and IUC™

- Designed for use in tapered holes.
- Tapered mounting hole allows for rapid and accurate alignment prior to installation.

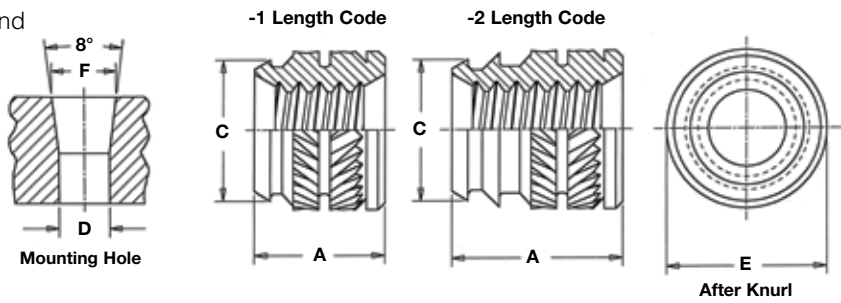

All dimensions are in inches.

UNIFIED	Thread Size	Type		Thread Code (1)	Length Code	A ± .005	E ± .005	C ± .005	Hole Size in Material		
		Brass	Stainless Steel						Min. Hole Depth	D ± .002	F ± .002
				2	.188		.115	.228	.107		
.086-56 (#2-56)	IUB	IUC	256 <sup>(2)</sup>	1	.115	.141	.123	.155	.118	.123	
				2	.188		.115	.228	.107		
.112-40 (#4-40)	IUB	IUC	440	1	.135	.172	.157	.175	.153	.159	
				2	.219		.149	.259	.141		
.138-32 (#6-32)	IUB	IUC	632	1	.150	.219	.203	.190	.199	.206	
				2	.250		.190	.290	.185		
.164-32 (#8-32)	IUB	IUC	832	1	.185	.250	.230	.225	.226	.234	
				2	.312		.213	.352	.208		
.190-24 (#10-24)	IUB	IUC	024	1	.225	.297	.272	.265	.267	.277	
				2	.375		.251	.415	.246		
.190-32 (#10-32)	IUB	IUC	032	1	.225	.297	.272	.265	.267	.277	
				2	.375		.251	.415	.246		
.250-20 (1/4-20)	IUB	IUC	0420	1	.300	.375	.354	.340	.349	.363	
				2	.500		.332	.540	.321		
.250-28 (1/4-28)	IUB	IUC	0428	1	.300	.375	.354	.340	.349	.363	
				2	.500		.332	.540	.321		
.313-18 (5/16-18)	IUB	IUC	0518	1	.335	.469	.439	.375	.431	.448	
				2	.562		.406	.602	.401		
.375-16 (3/8-16)	IUB	IUC	0616	1	.375	.563	.532	.415	.523	.540	
				2	.625		.493	.665	.488		

All dimensions are in millimeters.

METRIC	Thread Size x Pitch	Type		Thread Code (1)	Length Code	A ± 0.13	E ± 0.13	C ± 0.13	Hole Size in Material		
		Brass	Stainless Steel						Min. Hole Depth	D ± 0.05	F ± 0.05
				2	5.56		3.79	6.58	3.58		
M3 x 0.5	IUB	IUC	M3	1	3.43	4.37	3.99	4.44	3.89	4.04	
				2	5.56		3.79	6.58	3.58		
M3 x 0.5	IUBB	IUCC	M3	1	3.81	5.56	5.16	4.83	5.05	5.23	
				2	6.35		4.83	7.42	4.7		
M3.5 x 0.6	IUB	IUC	M3.5	1	3.81	5.56	5.16	4.83	5.05	5.23	
				2	6.35		4.83	7.42	4.7		
M4 x 0.7	IUB	IUC	M4	1	4.7	6.35	5.84	5.72	5.74	5.94	
				2	7.92		5.41	8.94	5.28		
M5 x 0.8	IUB	IUC	M5	1	5.72	7.54	6.91	6.74	6.78	7.03	
				2	9.53		6.38	10.55	6.25		
M5 x 0.8	IUBB	IUCC	M5	1	6.71	8.33	7.83	7.72	7.7	8	
				2	11.1		7.16	12.12	7.06		
M6 x 1	IUB	IUC	M6	1	7.62	9.52	8.99	8.64	8.86	9.22	
				2	12.7		8.43	13.72	8.15		
M8 x 1.25	IUB	IUC	M8	1	8.51	11.91	11.15	9.53	10.95	11.38	
				2	14.27		10.31	15.29	10.19		

(1) Thread tapped thru, Class 3A/4h screw must pass with finger torque, but basic go gauge may stop at last thread.

(2) Diamond knurl.

# ULTRASONIC / HEAT STAKING INSERTS

## Straight Wall, Thru-Threaded, Types IUTB™ and IUTC™

- Designed for use in straight holes.
- Self-aligning lead-in of insert provides for accurate alignment prior to installation.

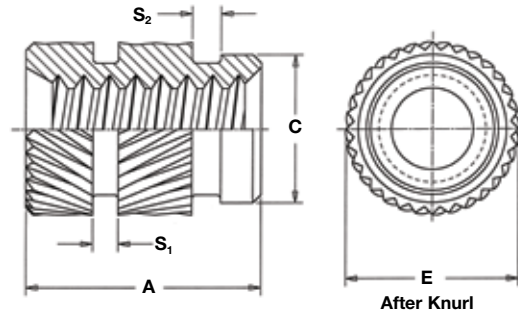

All dimensions are in inches.

UNIFIED	Thread Size	Type		Thread Code (1)	A ± .005	E ± .009	C ± .005	S <sub>1</sub> Nom.	S <sub>2</sub> Nom.	Hole Size in Material	
		Brass	Stainless Steel							Min. Hole Depth	Hole Dia. + .003 - .000
	.086-56 (#2-56)	IUTB	IUTC	256	.157	.147	.121	.031	.031	.187	.127
	.112-40 (#4-40)	IUTB	IUTC	440	.226	.179	.152	.031	.031	.256	.158
	.138-32 (#6-32)	IUTB	IUTC	632	.281	.210	.183	.031	.031	.311	.189
	.164-32 (#8-32)	IUTB	IUTC	832	.321	.243	.217	.031	.040	.351	.223
	.190-24 (#10-24)	IUTB	IUTC	024	.375	.273	.247	.046	.046	.405	.253
	.190-32 (#10-32)	IUTB	IUTC	032	.375	.273	.247	.046	.046	.405	.253
	.250-20 (1/4-20)	IUTB	IUTC	0420	.500	.342	.310	.046	.062	.530	.316
	.250-28 (1/4-28)	IUTB	IUTC	0428	.500	.342	.310	.046	.062	.530	.316
	.375-16 (3/8-16)	IUTB	IUTC	0616	.500	.509	.462	.046	.062	.530	.468

All dimensions are in millimeters.

METRIC	Thread Size x Pitch	Type		Thread Code (1)	A ± 0.13	E ± 0.23	C ± 0.13	S <sub>1</sub> Nom.	S <sub>2</sub> Nom.	Hole Size in Material	
		Brass	Stainless Steel							Min. Hole Depth	Hole Dia. + 0.08
	M2 x 0.4	IUTB	IUTC	M2	4	3.73	3.07	0.79	0.79	4.76	3.23
	M2.5 x 0.45	IUTB	IUTC	M2.5	5.74	4.55	3.86	0.79	0.79	6.5	4.01
	M3 x 0.5	IUTB	IUTC	M3	5.74	4.55	3.86	0.79	0.79	6.5	4.01
	M3.5 x 0.6	IUTB	IUTC	M3.5	7.14	5.33	4.65	0.79	0.79	7.9	4.81
	M4 x 0.7	IUTB	IUTC	M4	8.15	6.17	5.51	0.79	1.02	8.91	5.67
	M5 x 0.8	IUTB	IUTC	M5	9.52	6.93	6.27	1.17	1.17	10.28	6.43
	M6 x 1	IUTB	IUTC	M6	12.7	8.69	7.87	1.17	1.58	13.46	8.03

(1) Thread tapped thru, Class 3A/4h screw must pass with finger torque, but basic go gauge may stop at last thread.

# ULTRASONIC / HEAT STAKING INSERTS

## Symmetrical, Thru-Threaded, Types ISB™ and ISC™

- Designed for use in straight or tapered holes.
- Symmetrical design eliminates the need for orientation.

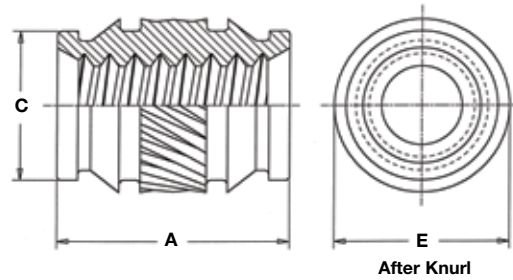

All dimensions are in inches.

UNIFIED	Thread Size	Type		Thread Code (1)	A ± .005	E ± .005	C ± .003	Hole Size in Material	
		Brass	Stainless Steel					Hole Depth	Hole Dia. +.003-.000
	.086-56 (#2-56)	ISB	ISC	256	.157	.151	.122	.187	.126
.112-40 (#4-40)	ISB	ISC	440	.226	.182	.153	.256	.157	
.138-32 (#6-32)	ISB	ISC	632	.281	.215	.184	.311	.188	
.164-32 (#8-32)	ISB	ISC	832	.321	.245	.217	.351	.221	
.190-32 (#10-32)	ISB	ISC	032	.375	.276	.248	.405	.252	
.250-20 (1/4-20)	ISB	ISC	0420	.500	.338	.311	.530	.315	

All dimensions are in millimeters.

METRIC	Thread Size x Pitch	Type		Thread Code (1)	A ± 0.13	E ± 0.13	C ± 0.08	Hole Size in Material	
		Brass	Stainless Steel					Hole Depth	Hole Dia. +0.08
	M3 x 0.5	ISB	ISC	M3	5.74	4.62	3.88	6.5	3.99
M4 x 0.7	ISB	ISC	M4	8.15	6.22	5.51	8.92	5.62	
M5 x 0.8	ISB	ISC	M5	9.52	7.01	6.3	10.29	6.4	
M6 x 1	ISB	ISC	M6	12.7	8.58	7.9	13.46	8	

(1) Thread tapped thru, Class 3A/4h screw must pass with finger torque, but basic go gauge may stop at last thread.

# ULTRASONIC THREADED INSERTS PERFORMANCE DATA

## Types IUB, IUBB, IUC, and IUCC<sup>(1)</sup>

UNIFIED	Thread Code	ABS		Polycarbonate	
		Pullout (lbs.)	Torque-out (in. lbs.)	Pullout (lbs.)	Torque-out (in. lbs.)
080-1	75	3	90	3	
256-1	75	3	90	6	
256-2	75	3	90	6	
440-1	80	4	160	7	
440-2	80	4	160	7	
632-1	145	15	165	18	
632-2	275	15	450	24	
832-1	205	18	295	20	
832-2	370	19	645	20	
024-1	270	45	430	55	
024-2	560	60	910	80	
032-1	270	45	430	55	
032-2	560	60	910	80	
0420-1	374	65	614	85	
0420-2	680	65	1415	108	

METRIC	Thread Code	ABS		Polycarbonate	
		Pullout (N)	Torque-out (N•m)	Pullout (N)	Torque-out (N•m)
M2.5-1	334	0.3	400	0.7	
M2.5-2	334	0.3	400	0.7	
M3-1	356	0.5	712	0.8	
M3-2	356	0.5	712	0.8	
M3.5-1	645	1.7	734	2	
M3.5-2	1223	1.7	2002	2.7	
M4-1	912	2	1312	2.3	
M4-2	1646	2.1	2869	2.3	
M5-1	1201	5.1	1913	6.2	
M5-2	2491	6.8	4048	9	
M6-1	1664	7.3	2731	9.6	
M6-2	3025	7.3	6294	12.2	

## Types IUTB, IUTC<sup>(1)</sup>

UNIFIED	Thread Code	ABS		Polycarbonate	
		Pullout (lbs.)	Torque-out (in. lbs.)	Pullout (lbs.)	Torque-out (in. lbs.)
256	90	6	112	8	
440	165	14	245	16	
632	268	25	295	31	
832	328	36	385	52	
032	385	54	565	80	
0420	480	135	600	190	

METRIC	Thread Code	ABS		Polycarbonate	
		Pullout (N)	Torque-out (N•m)	Pullout (N)	Torque-out (N•m)
M2.5/M3	730	1.58	1080	1.81	
M4	1450	4.07	1710	5.88	
M5	1710	6.1	2510	9.04	
M6	2130	15.26	2660	21.47	

## Types ISB and ISC<sup>(1)</sup>

UNIFIED	Thread Code	ABS		Polycarbonate	
		Pullout (lbs.)	Torque-out (in. lbs.)	Pullout (lbs.)	Torque-out (in. lbs.)
256	85.5	6.14	149.4	6.37	
440	151.37	14.38	344.94	23.17	
632	320.3	21.69	405.9	18.19	
832	462.9	31.7	663.9	57.15	
032	549.6	52.3	1015.4	71.79	
0420	600.45	100.25	-	-	

METRIC	Thread Code	ABS		Polycarbonate	
		Pullout (N)	Torque-out (N•m)	Pullout (N)	Torque-out (N•m)
M3	680	1.62	1550	2.6	
M4	2080	3.58	2980	6.45	
M5	2470	5.9	4560	8.11	
M6	2700	11.1	-	-	

(1) The values reported are averages for ultrasonically inserted inserts when all installation specifications and procedures are followed. Variations in mounting hole size, sheet material and installation procedure will affect results. Performance testing of this product in your application is recommended. Samples can be provided for this purpose.

# MOLDED-IN THREADED INSERTS

## Blind Threaded, Types IBB™ and IBC™

- Blind-end protects the threads from plastic intrusion.



**NOTE:** Manufacturing techniques may leave a slight projection a maximum of .025" / 0.65 mm beyond the "A" dimension.

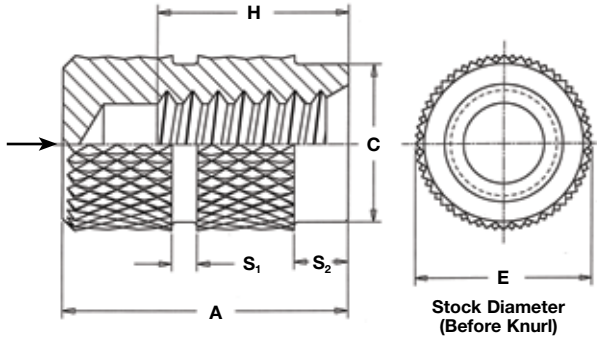

All dimensions are in inches.

UNIFIED	Thread Size	Type		Thread Code	Length Code A ± .005/H Min.					E Nom.	C ± .005	S <sub>1</sub> Nom.	S <sub>2</sub> Nom.	Minor Dia. Min./Max.
		Brass	Stainless Steel		4	6	8	10	12					
	.086-56 (#2-56)	IBB	IBC	256	.156/.080	.219/.115	.250/.150	.312/.185	.344/.220	.156	.142	.03	.03	.067/.0737
.112-40 (#4-40)	IBB	IBC	440	.205/.110	.281/.160	.344/.210	.406/.260	.438/.310	.188	.171	.03	.03	.086/.0939	
.138-32 (#6-32)	IBB	IBC	632	.250/.135	.344/.200	.406/.260	.469/.325	.531/.385	.219	.202	.03	.06	.105/.114	
.164-32 (#8-32)	IBB	IBC	832	.250/.135	.344/.200	.406/.260	.469/.325	.531/.385	.250	.226	.05	.06	.131/.139	
.190-24 (#10-24)	IBB	IBC	024	.356/.175	.438/.260	.531/.345	.625/.425	.716/.510	.281	.259	.05	.06	.146/.156	
.190-32 (#10-32)	IBB	IBC	032	.281/.135	.438/.200	.531/.260	.469/.325	.531/.385	.281	.259	.05	.06	.157/.164	
.250-20 (1/4-20)	IBB	IBC	0420	.344/.200	.531/.315	.625/.415	.719/.515	.819/.615	.344	.321	.06	.09	.197/.207	
.313-18 (5/16-18)	IBB	IBC	0518	.438/.235	.594/.345	.719/.460	.811/.570	.949/.680	.438	.404	.078	.094	.260/.265	
.375-16 (3/8-16)	IBB	IBC	0616	.500/.265	.688/.390	.812/.515	.935/.640	1.00/.765	.500	.466	.094	.094	.309/.321	

All dimensions are in millimeters.

METRIC	Thread Size x Pitch	Type		Thread Code	Length Code A ± 0.13/H Min.					E Nom.	C ± 0.13	S <sub>1</sub> Nom.	S <sub>2</sub> Nom.	Minor Dia. Min./Max.
		Brass	Stainless Steel		4	6	8	10	12					
	M2.5 x 0.45	IBB	IBC	M2.5	4.78/2.01	6.35/2.87	7.14/3.74	9.53/4.6	10.31/5.47	4.78	4.34	0.8	0.8	2.03/2.14
M3 x 0.5	IBB	IBC	M3	5.21/2.21	7.13/3.21	8.73/4.21	10.31/5.21	11.13/6.21	4.78	4.34	0.8	0.8	2.47/2.59	
M3.5 x 0.6	IBB	IBC	M3.5	6.35/2.62	8.73/3.81	10.31/5.02	11.91/6.22	13.48/7.42	5.56	5.13	0.8	1.6	2.87/3.01	
M4 x 0.7	IBB	IBC	M4	6.35/3.08	8.73/4.47	10.31/5.89	11.91/7.29	13.48/8.69	6.35	5.74	1.2	1.6	3.25/3.42	
M5 x 0.8	IBB	IBC	M5	7.13/3.49	11.12/5.09	13.48/6.69	11.91/8.29	13.48/9.89	7.14	6.57	1.2	1.6	4.15/4.34	
M6 x 1	IBB	IBC	M6	8.73/4.37	13.49/6.37	15.87/8.37	18.26/10.57	20.8/12.37	8.74	8.15	1.6	2.4	4.94/5.16	
M8 x 1.25	IBB	IBC <sup>MS</sup>	M8	11.13/5.72	15.09/7.82	18.24/10.32	20.62/12.82	22.23/15.32	11.13	10.26	1.98	2.4	6.78/6.92	



# MOLDED-IN THREADED INSERTS

## Self-Locking, Blind Threaded, Type IBLC™

- Deformed threads lock screw in place to resist vibration.
- Blind-end protects the threads from plastic intrusion.



**NOTE:** Manufacturing techniques may leave a slight projection a maximum of .025" / 0.65 mm beyond the "A" dimension.

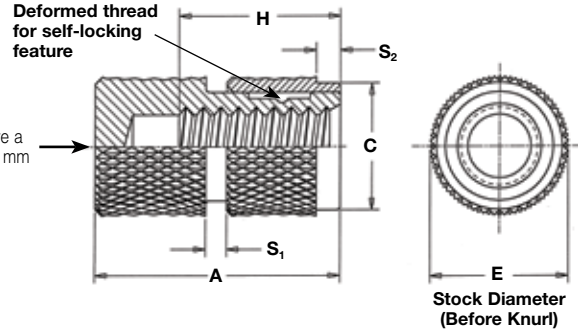

All dimensions are in inches.

UNIFIED	Thread Size	Type	Thread Code	Length Code	A ± .005	E Nom.	C ± .005	S <sub>1</sub> ± .005	S <sub>2</sub> ± .005	(1) Minor Dia. Min/Max	H Min.	First Cycle on Locking Torque (in. lbs.)	
	Stainless Steel											Min.	Max.
	.086-56 (#2-56)	IBLC	256	8	.250	.156	.150	.03	.03	.067/.0737	.150	0.2	2.5
.112-40 (#4-40)	IBLC	440	8	.344	.188	.180	.03	.03	.086/.0939	.210	0.5	5	
.138-32 (#6-32)	IBLC	632	8	.406	.219	.200	.03	.03	.105/.114	.260	1	10	
.164-32 (#8-32)	IBLC	832	8	.406	.250	.235	.05	.06	.131/.139	.260	1.5	15	
.190-32 (#10-32)	IBLC	032	8	.531	.281	.270	.05	.06	.157/.164	.260	2	18	
.250-20 (1/4-20)	IBLC	0420	8	.625	.344	.325	.06	.09	.197/.207	.415	4.5	30	

All dimensions are in millimeters.

METRIC	Thread Size x Pitch	Type	Thread Code	Length Code	A ± 0.13	E Nom.	C ± 0.13	S <sub>1</sub> ± 0.13	S <sub>2</sub> ± 0.13	(1) Minor Dia. Min/Max	H Min.	First Cycle on Locking Torque (N•m)	
	Stainless Steel											Min.	Max.
	M3 x 0.5	IBLC	M3	8	8.73	4.78	4.57	0.8	0.8	2.48/2.59	4.21	0.06	0.6
M4 x 0.7	IBLC	M4	8	10.31	6.35	5.97	1.2	1.6	3.26/3.42	5.89	0.16	1.6	
M5 x 0.8	IBLC	M5	8	13.48	7.14	6.86	1.2	1.6	4.15/4.34	6.69	0.23	2.1	
M6 x 1	IBLC	M6	8	15.87	8.73	8.26	1.6	2.4	4.95/5.15	8.37	0.37	3.2	

(1) Minor diameter may be below minimum in deformed thread area.

# MOLDED-IN THREADED INSERTS

## Thru-Threaded, Types ITB™ and ITC™

- Pilot diameter and undercuts allow plastic to flow into grooves providing high pullout resistance.

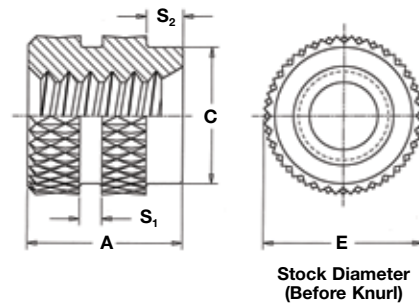

All dimensions are in inches.

UNIFIED	Thread Size	Type		Thread Code (1)	A ± .005	E Nom.	C ± .005	S <sub>1</sub> Nom.	S <sub>2</sub> Nom.	Minor Dia. Min./Max.
		Brass	Stainless Steel							
	.060-80 (#0-80)	ITB	ITC	080	.125	.109	.078	.03	.03	.0475/.051
	.086-56 (#2-56)	ITB	ITC	256	.125	.156	.142	.03	.03	.067/.0737
	.112-40 (#4-40)	ITB	ITC	440	.188	.188	.171	.03	.03	.086/.0939
	.138-32 (#6-32)	ITB	ITC	632	.219	.219	.202	.03	.06	.105/.114
	.164-32 (#8-32)	ITB	ITC	832	.250	.250	.226	.05	.06	.131/.139
	.190-24 (#10-24)	ITB	ITC	024	.281	.281	.259	.05	.06	.146/.156
	.190-32 (#10-32)	ITB	ITC	032	.281	.281	.259	.05	.06	.157/.164
	.250-20 (1/4-20)	ITB	ITC	0420	.375	.344	.321	.06	.09	.197/.207
	.250-28 (1/4-28)	ITB	ITC	0428	.375	.344	.321	.06	.09	.212/.220
	.313-18 (5/16-18)	ITB	ITC	0518	.469	.437	.404	.08	.09	.260/.265
	.375-16 (3/8-16)	ITB	ITC	0616	.562	.500	.466	.09	.09	.309/.321

All dimensions are in millimeters.

METRIC	Thread Size x Pitch	Type		Thread Code (1)	A ± 0.13	E Nom.	C ± 0.13	S <sub>1</sub> Nom.	S <sub>2</sub> Nom.	Minor Dia. Min./Max.
		Brass	Stainless Steel							
	M3 x 0.5	ITB	ITC	M3	4.77	4.77	4.34	0.78	0.78	2.47/2.59
	M4 x 0.7	ITB	ITC	M4	6.35	6.35	5.74	1.16	1.57	3.25/3.42
	M5 x 0.8	ITB	ITC	M5	7.13	7.13	6.57	1.16	1.57	4.15/4.34
	M6 x 1	ITB	ITC	M6	9.53	8.74	8.15	1.57	2.38	4.94/5.16
	M10 x 1.5	ITB	ITC	M10	14.27	12.7	11.84	2.38	2.38	8.55/8.67

(1) Thread tapped thru, Class 3A/4h screw must pass with finger torque, but basic go gauge may stop at last thread.

# MOLDED-IN THREADED INSERTS

## Thru-Threaded, Knurled, Types STKB™ and STKC™

- Uniform knurl diameter reduces the risk of sink marks.
- Available in varying lengths for injection molding assemblies.

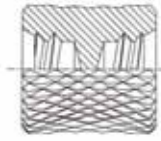

Configuration for  
STKB/STKC-256-20 and -24

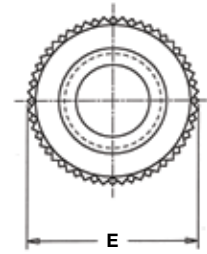
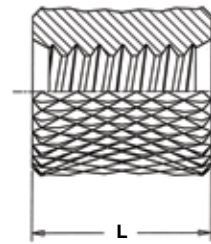

Stock Diameter  
(Before Knurl)

All dimensions are in inches.

UNIFIED	Thread Size	Type		Thread Code (1)	Length Code "L" ± .005 in 32nds of an Inch							E Nom.	Minor Dia. Min./Max.
		Brass	Stainless Steel		.125	.187	.250	.312	.375	.500	.625		
	.086-56 (#2-56)	STKB	STKC	256	4	6	8	10	12	16	20	24	.156
.112-40 (#4-40)	STKB	STKC	440	4	6	8	10	12	16	20	24	.188	.086/.0939
.138-32 (#6-32)	STKB	STKC	632	4	6	8	10	12	16	20	24	.219	.105/.114
.164-32 (#8-32)	STKB	STKC	832	4	6	8	10	12	16	20	24	.250	.131/.139
.190-32 (#10-32)	STKB	STKC	032	4	6	8	10	12	16	20	24	.281	.157/.164
.250-20 (1/4-20)	STKB	STKC	0420	4	6	8	10	12	16	20	24	.375	.197/.207
.313-18 (5/16-18)	STKB	STKC	0518	4	6	8	10	12	16	20	24	.437	.260/.265
.375-16 (3/8-16)	STKB	STKC	0616	4	6	8	10	12	16	20	NA	.500	.309/.321

All dimensions are in millimeters.

METRIC	Thread Size x Pitch	Type		Thread Code (1)	Length Code "L" ± 0.13 in millimeters							E Nom.	Minor Dia. Min./Max.
		Brass	Stainless Steel		3	4	6	8	10	12	15		
M3 x 0.5	STKB	STKC	M3	3	4	6	8	10	12	15	18	4.74	2.47/2.59
M4 x 0.7	STKB	STKC	M4	3	4	6	8	10	12	15	18	6.35	3.25/3.42
M5 x 0.8	STKB	STKC	M5	3	4	6	8	10	12	15	18	7.13	4.15/4.34

(1) Thread tapped thru, Class 3A/4h screw must pass with finger torque, but basic go gauge may stop at last thread.  
NA Not Available.

# MOLDED-IN THREADED INSERTS PERFORMANCE DATA

## Types IBB and IBC<sup>(1)</sup>

UNIFIED	Thread Code	Length Code	ABS		Polycarbonate	
			Pullout (lbs.)	Torque-out (in. lbs.)	Pullout (lbs.)	Torque-out (in. lbs.)
			256	6	148 / 140	5.8 / 5.5
	10	150 / 143	6 / 5.7	167 / 160	6.4 / 5.9	
440	6	250 / 240	6.2 / 5.7	265 / 253	6.9 / 6.5	
	10	252 / 243	6.4 / 5.9	268 / 262	7 / 6.6	
632	6	425 / 415	8.5 / 8	455 / 440	9.2 / 8.7	
	10	428 / 420	8.6 / 8.2	458 / 452	9.3 / 8.8	
832	6	530 / 521	15 / 14.1	545 / 536	16.1 / 15.4	
	10	533 / 526	15.8 / 15	547 / 540	16.4 / 15.8	
032	6	635 / 624	57 / 52	648 / 640	59 / 56	
	10	637 / 629	58 / 54	651 / 646	60 / 57	
0420	6	910 / 895	108 / 103	928 / 912	111 / 107	

METRIC	Thread Code	Length Code	ABS		Polycarbonate	
			Pullout (N)	Torque-out (N•m)	Pullout (N)	Torque-out (N•m)
			M2.5/M3	6	1110 / 1060	0.7 / 0.64
	10	1120 / 1080	0.72 / 0.66	1190 / 1160	0.79 / 0.74	
M4	6	2350 / 2310	1.69 / 1.59	2420 / 2380	1.81 / 1.74	
	10	2370 / 2330	1.78 / 1.69	2430 / 2400	1.85 / 1.79	
M5	6	2820 / 2770	6.44 / 5.87	2880 / 2840	6.66 / 6.32	
	10	2830 / 2790	6.55 / 6.1	2890 / 2870	6.78 / 6.44	
M6	6	4040 / 3980	12.2 / 11.6	4120 / 4050	12.5 / 12	

## Types IBLC<sup>(1)</sup>

UNIFIED	Thread Code	ABS		Polycarbonate	
		Pullout (lbs.)	Torque-out (in. lbs.)	Pullout (lbs.)	Torque-out (in. lbs.)
		256	128 / 118	5 / 4.6	142 / 134
440	230 / 220	6 / 5.5	238 / 226	6.8 / 6.2	
632	392 / 378	7.8 / 7	406 / 390	9 / 8.2	
832	496 / 480	11 / 9	500 / 468	14 / 13	
032	592 / 580	40 / 30	592 / 564	48 / 42	
0420	760 / 738	90 / 78	798 / 780	99 / 84	

METRIC	Thread Code	ABS		Polycarbonate	
		Pullout (N)	Torque-out (N•m)	Pullout (N)	Torque-out (N•m)
		M3	1020 / 970	0.67 / 0.62	1050 / 1000
M4	2200 / 2130	1.24 / 1.01	2220 / 2080	1.58 / 1.46	
M5	2630 / 2570	4.52 / 3.39	2630 / 2500	5.42 / 4.74	
M6	3380 / 3280	10.1 / 8.81	3540 / 3460	11.1 / 9.49	

## Types ITB and ITC<sup>(1)</sup>

UNIFIED	Thread Code	ABS		Polycarbonate	
		Pullout (lbs.)	Torque-out (in. lbs.)	Pullout (lbs.)	Torque-out (in. lbs.)
		080/256	104 / 96	5.6 / 5.2	115 / 106
440	175 / 166	6 / 5.5	186 / 173	6.9 / 6.2	
632	298 / 290	8 / 7.5	318 / 302	9 / 8.5	
832	370 / 368	14 / 13.6	382 / 372	16 / 14.7	
032	444 / 432	55 / 50	454 / 445	57 / 52	
0420/0428	635 / 620	75 / 70	650 / 635	103 / 98	

METRIC	Thread Code	ABS		Polycarbonate	
		Pullout (N)	Torque-out (N•m)	Pullout (N)	Torque-out (N•m)
		M3	770 / 730	0.67 / 0.62	820 / 760
M4	1640 / 1630	1.58 / 1.53	1690 / 1650	1.8 / 1.66	
M5	1970 / 1920	6.22 / 5.65	2010 / 1970	6.44 / 5.87	
M6	2820 / 2750	8.47 / 7.91	2890 / 2820	11.6 / 11	

(1) The values reported are high and low ranges when all installation specifications and procedures are followed. Variations in mounting hole size, workpiece material and installation procedure will affect results. Performance testing of this product in your application is recommended. Samples can be provided for this purpose.

# PRESS-IN THREADED INSERTS

## Hexagonal, Types NFPA™ and NFPC™

- Press-fit insert provides strong, reusable threads. No heat or ultrasonics required.
- Hexagonal “barbed” configuration ensures high torque-out and pullout values.

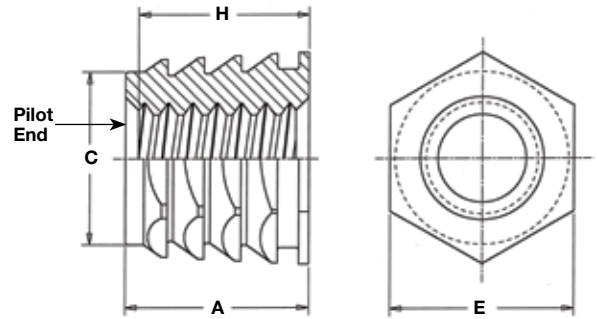

All dimensions are in inches.

UNIFIED	Thread Size	Type		Thread Code	A Max.	Min. Sheet Thickness	Hole Size in Sheet + .003 - .000	C Max.	E Nom.	Min. Boss Dia.	Min. Depth Full Thread H <sup>(1)</sup>
		Stainless Steel	Aluminum								
	.086-56 (#2-56)	NFPC	NFPA	256	.230	.240	.187	.186	.187	.500	.212
	.112-40 (#4-40)	NFPC	NFPA	440	.230	.240	.187	.186	.187	.500	.212
	.138-32 (#6-32)	NFPC	NFPA	632	.230	.240	.187	.186	.187	.500	.212
	.164-32 (#8-32)	NFPC	NFPA	832	.265	.275	.250	.249	.250	.625	.248
	.190-24 (#10-24)	NFPC	NFPA	024	.265	.275	.250	.249	.250	.625	.248
	.190-32 (#10-32)	NFPC	NFPA	032	.265	.275	.250	.249	.250	.625	.248
	.250-20 (1/4-20)	NFPC	NFPA	0420	.315	.328	.312	.311	.312	.750	.300
	.313-18 (5/16-18)	NFPC	NFPA	0518	.365	.380	.375	.374	.375	.950	.345

All dimensions are in millimeters.

METRIC	Thread Size x Pitch	Type		Thread Code	A Max.	Min. Sheet Thickness	Hole Size in Sheet + 0.08	C Max.	E Nom.	Min. Boss Dia.	Min. Depth Full Thread H <sup>(1)</sup>
		Stainless Steel	Aluminum								
	M3 x 0.5	NFPC	NFPA	M3	5.84	6.1	4.75	4.72	4.75	12.7	5.38
	M3.5 x 0.6	NFPC	NFPA	M3.5	5.84	6.1	4.75	4.72	4.75	12.7	5.38
	M4 x 0.7	NFPC	NFPA	M4	6.73	6.99	6.35	6.32	6.35	15.88	6.3
	M5 x 0.8	NFPC	NFPA	M5	6.73	6.99	6.35	6.32	6.35	15.88	6.3
	M6 x 1	NFPC	NFPA	M6	8	8.33	7.92	7.89	7.92	19.05	7.62
	M8 x 1.25	NFPC	NFPA	M8	9.27	9.65	9.53	9.50	9.53	24.13	8.76

(1) Thread tapped thru, Class 3A/4h screw must pass with finger torque, but basic go gauge may stop at pilot end.

# PRESS-IN THREADED INSERTS

## Thru-Threaded, Type PPB™

- Press-fit insert with strong, reusable threads.
- No heat or ultrasonics required.
- Slotted insert compresses allowing easy access into the mounting hole.

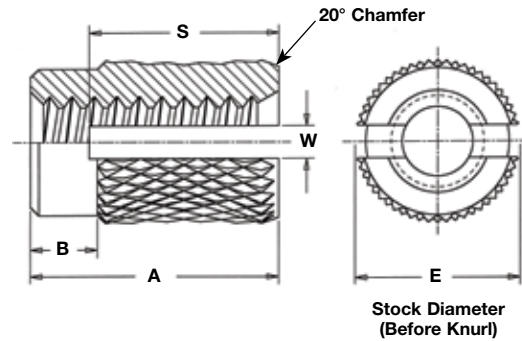

All dimensions are in inches.

UNIFIED	Thread Size	Type	Thread Code	Length Code	A ± .005	E Nom.	B ± .015	S Nom.	W ± .015	Hole Size in Material	
		Brass								Min. Hole Depth	Hole Dia. ± .002
	.086-56 (#2-56)	PPB	256	1	.156	.125	.040	.115	.020	.196	.125
.112-40 (#4-40)	PPB	440	1	.188	.156	.045	.140	.020	.228	.156	
			2	.250		.060	.190		.290		
.138-32 (#6-32)	PPB	632	1	.250	.188	.060	.190	.031	.290	.188	
			2	.313		.075	.235		.353		
.164-32 (#8-32)	PPB	832	1	.250	.219	.060	.190	.047	.290	.219	
			2	.313		.075	.235		.353		
.190-32 (#10-32)	PPB	032	1	.313	.250	.075	.235	.062	.353	.250	
			2	.375		.090	.280		.415		
.250-20 (1/4-20)	PPB	0420	1	.438	.313	.105	.330	.078	.478	.313	
			2	.500		.120	.375		.540		

All dimensions are in millimeters.

METRIC	Thread Size x Pitch	Type	Thread Code	Length Code	A ± 0.13	E Nom.	B ± 0.4	S Nom.	W ± 0.4	Hole Size in Material	
		Brass								Min. Hole Depth	Hole Dia. ± 0.05
	M3 x 0.5	PPB	M3	1	4.77	3.96	1.14	3.56	0.5	5.79	3.96
2				6.35	1.52		4.83	7.37			
M4 x 0.7	PPB	M4	1	6.35	5.56	1.52	4.83	1.2	7.37	5.56	
			2	7.95		1.91	5.97		8.97		
M5 x 0.8	PPB	M5	1	7.95	6.35	1.91	5.97	1.6	8.97	6.35	
			2	9.52		2.29	7.11		10.54		
M6 x 1	PPB	M6	1	11.12	7.95	2.67	8.38	2	12.14	7.95	
			2	12.7		3.05	9.53		13.72		

# PRESS-IN THREADED INSERTS

## Flange-Head, Type PFLB™

- Press-fit insert with strong, reusable threads. No heat or ultrasonics required.
- Flange-head eliminates direct contact of plastic with mating parts.
- Slotted insert compresses allowing easy access into the mounting hole

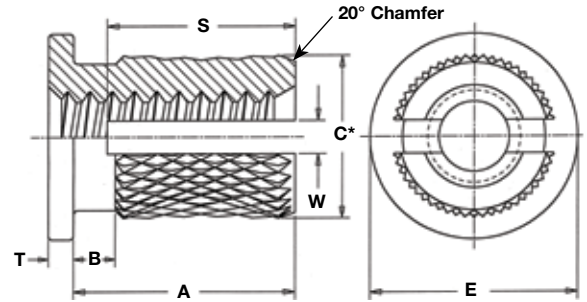

\*C Diameter (After Knurl)

All dimensions are in inches.

UNIFIED	Thread Size	Type Brass	Thread Code	Length Code	A ± .005	E Nom.	C Nom.	T ± .005	B ± .010	S Nom.	W ± .015	Hole Size in Material	
												Min. Hole Depth	Hole Dia. ± .002
.086-56 (#2-56)	PFLB	256	1	.136	.188	.135	.020	.025	.115	.020	.176	.125	
.112-40 (#4-40)	PFLB	440	1	.166	.219	.166	.022	.027	.140	.020	.206	.156	
			2	.228									.268
.138-32 (#6-32)	PFLB	632	1	.222	.250	.200	.028	.033	.190	.031	.262	.188	
			2	.253									.293
.164-32 (#8-32)	PFLB	832	1	.246	.281	.230	.035	.040	.210	.047	.286	.219	
			2	.278									.318
.190-32 (#10-32)	PFLB	032	1	.270	.313	.262	.043	.048	.235	.062	.310	.250	
			2	.332									.372
.250-20 (1/4-20)	PFLB	0420	1	.388	.375	.335	.050	.055	.330	.078	.428	.313	
			2	.450									.490

All dimensions are in millimeters.

METRIC	Thread Size x Pitch	Type Brass	Thread Code	Length Code	A ± 0.13	E Nom.	C Nom.	T ± 0.13	B ± 0.25	S Nom.	W ± 0.4	Hole Size in Material	
												Min. Hole Depth	Hole Dia. ± 0.05
M3 x 0.5	PFLB	M3	1	4.22	5.56	4.22	0.56	0.69	3.56	0.5	5.24	3.96	
			2	5.8									6.82
M4 x 0.7	PFLB	M4	1	6.25	7.14	5.84	0.89	1.02	5.33	1.14	7.27	5.56	
			2	7.06									8.08
M5 x 0.8	PFLB	M5	1	6.86	7.95	6.65	1.09	1.22	5.97	1.6	7.88	6.35	
			2	8.43									9.45
M6 x 1	PFLB	M6	1	9.86	9.53	8.51	1.27	1.40	8.38	2	10.88	7.95	
			2	11.43									12.45

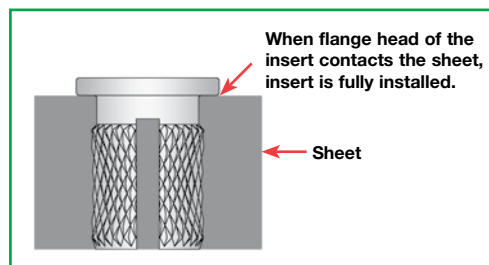

# PRESS-IN THREADED INSERTS

## Straight Knurl, Type PKB™

- Press-fit insert with strong, reusable threads.
- No heat or ultrasonics required.
- Straight knurling at the top end of the insert offers higher torsional resistance.
- Slotted insert compresses allowing easy access into the mounting hole.

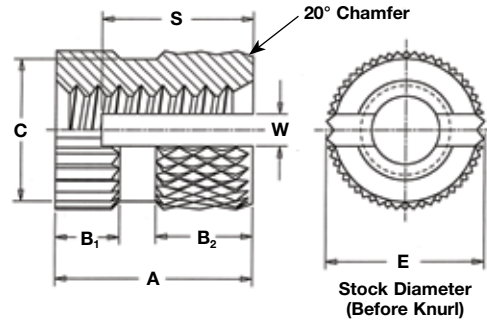

All dimensions are in inches.

UNIFIED	Thread Size	Type	Thread Code	A ± .005	E Nom.	C ± .010	B <sub>1</sub> ± .010	B <sub>2</sub> ± .010	S Nom.	W ± .015	Hole Size in Material	
		Brass									Min. Hole Depth	Hole Dia. ± .002
	.086-56 (#2-56)	PKB	256	.125	.125	.110	.037	.053	.095	.020	.165	.125
.112-40 (#4-40)	PKB	440	.188	.156	.137	.056	.079	.140	.020	.228	.156	
.138-32 (#6-32)	PKB	632	.250	.188	.165	.075	.105	.190	.031	.290	.188	
.164-32 (#8-32)	PKB	832	.312	.219	.196	.094	.131	.235	.047	.352	.219	
.190-32 (#10-32)	PKB	032	.375	.250	.234	.112	.158	.280	.062	.415	.250	
.250-20 (1/4-20)	PKB	0420	.500	.312	.291	.150	.210	.375	.078	.540	.312	

All dimensions are in millimeters.

METRIC	Thread Size x Pitch	Type	Thread Code	A ± 0.13	E Nom.	C ± 0.25	B <sub>1</sub> ± 0.25	B <sub>2</sub> ± 0.25	S Nom.	W ± 0.4	Hole Size in Material	
		Brass									Min. Hole Depth	Hole Dia. ± 0.05
	M3 x 0.5	PKB	M3	4.78	3.96	3.48	1.42	2.01	3.56	0.5	5.8	3.96
M4 x 0.7	PKB	M4	7.92	5.56	4.98	2.39	3.33	5.97	1.19	8.94	5.56	
M5 x 0.8	PKB	M5	9.53	6.35	5.94	2.84	4.01	7.11	1.57	10.55	6.35	
M6 x 1	PKB	M6	12.7	7.92	7.39	3.81	5.33	9.53	1.98	13.72	7.92	



# PRESS-IN THREADED INSERTS PERFORMANCE DATA

## Types NFPA and NFPC<sup>(1)</sup>

UNIFIED	Thread Code	ABS			Polycarbonate		
		Install. Force (lbs.)	Pullout (lbs.)	Torque-out (in. lbs.)	Install. Force (lbs.)	Pullout (lbs.)	Torque-out (in. lbs.)
	440	225	125	4	600	280	16
632	225	125	4	600	280	16	
832	300	135	10	600	380	42	
032	300	135	10	600	380	42	
0420	400	235	28	-	-	-	

METRIC	Thread Code	ABS			Polycarbonate		
		Install. Force (kN)	Pullout (N)	Torque-out (N • m)	Install. Force (kN)	Pullout (N)	Torque-out (N • m)
	M3	1	556	0.45	2.67	1245	1.8
M4	1.33	600	1.13	2.67	1690	4.74	
M5	1.33	600	1.13	2.67	1690	4.74	
M6	1.78	1045	3.16	-	-	-	

## Type PPB<sup>(1)</sup>

UNIFIED	Thread Code	Length Code	Phenolic		Polycarbonate	
			Pullout (lbs.)	Torque-out (in. lbs.)	Pullout (lbs.)	Torque-out (in. lbs.)
	256	1	60	12.8	52	7.2
440	1	81	20.8	74	15.3	
	2	193	38.6	170	25.2	
632	1	104	29.2	94	23.4	
	2	221	49.6	198	35.6	
832	1	126	36.8	116	31.6	
	2	249	59.8	224	45.6	
032	1	147	45.0	138	39.6	
	2	276	69.6	253	55.6	
0420	1	192	61.6	182	56.0	
	2	334	91.2	308	76.6	

METRIC	Thread Code	Length Code	Phenolic		Polycarbonate	
			Pullout (N)	Torque-out (N • m)	Pullout (N)	Torque-out (N • m)
	M3	1	360	2.35	330	1.73
2		860	4.36	760	2.85	
M4	1	560	4.16	520	3.57	
	2	1110	6.76	1000	5.15	
M5	1	650	5.09	610	4.47	
	2	1230	7.86	1130	6.28	
M6	1	850	6.96	810	6.33	
	2	1490	10.31	1370	8.66	

## Type PFLB<sup>(1)</sup>

UNIFIED	Thread Code	Length Code	Phenolic		Polycarbonate	
			Pullout (lbs.)	Torque-out (in. lbs.)	Pullout (lbs.)	Torque-out (in. lbs.)
	256	1	28	8.0	17	8.0
440	1	40	14.7	28	14.7	
	2	64	14.7	44	14.7	
632	1	53	22.0	41	22.0	
	2	77	22.0	56	22.0	
832	1	64	28.8	53	28.8	
	2	72	28.8	68	28.8	
032	1	76	35.6	65	35.6	
	2	100	35.6	80	35.6	
0420	1	100	49.8	89	49.8	
	2	125	49.8	104	49.8	

METRIC	Thread Code	Length Code	Phenolic		Polycarbonate	
			Pullout (N)	Torque-out (N • m)	Pullout (N)	Torque-out (N • m)
	M3	1	180	1.66	130	1.66
2		280	1.66	200	1.66	
M4	1	280	3.25	240	3.25	
	2	320	3.25	300	3.25	
M5	1	340	4.02	290	4.02	
	2	450	4.02	360	4.02	
M6	1	450	5.63	400	5.63	
	2	560	5.63	460	5.63	

## Type PKB<sup>(1)</sup>

UNIFIED	Thread Code	Phenolic		Polycarbonate	
		Pullout (lbs.)	Torque-out (in. lbs.)	Pullout (lbs.)	Torque-out (in. lbs.)
	256	22	13.2	11	5.2
440	42	22.2	32	14.4	
632	64	32.6	53	24.6	
832	84	42.0	73	33.8	
032	106	51.2	94	43.0	
0420	149	71.0	136	62.0	

METRIC	Thread Code	Phenolic		Polycarbonate	
		Pullout (N)	Torque-out (N • m)	Pullout (N)	Torque-out (N • m)
	M3	190	2.51	140	1.63
M4	370	4.75	320	3.82	
M5	470	5.79	420	4.86	
M6	660	8.02	610	7.01	

(1) The values reported are averages when all installation specifications and procedures are followed. Variations in mounting hole size, work piece material and installation procedure will affect results. Performance testing of this product in your application is recommended. Samples can be provided for this purpose.

## CUSTOM DESIGNS FOR SPECIAL APPLICATIONS

If you can not find a standard product in this catalog to meet your requirements, our Application Engineering Department will assist you to design a custom fastener to satisfy your requirements. Below are a few examples of custom insert designs.

### SNAP-TOP® ULTRASONIC INSERTS

Designed for ultrasonic installation allowing a spring action to hold a PC board securely without screws or other threaded hardware. SI ultrasonic SNAP-TOP® inserts are available in lengths from 1/4" to 1" / 6.35 to 25.4 mm spacing. These inserts can be provided in aluminum, brass, and stainless steel and are designed for ultrasonic installation into cored or drilled holes.

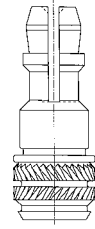

### THIN SHEET STUDS

Provide external threads in material as thin as .125" / 3.175 mm. SI studs are available in lengths from 1/4" to 3/4" / 6.35 to 19.05 mm in thread sizes #4-40 to 1/4-20 / M3 to M6. These inserts can be provided in aluminum, brass, steel and stainless steel and can be pressed into pre-molded or drilled holes.

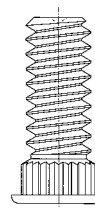

### ULTRASONIC STUDS

Tapered body provides easy insertion in pre-molded or drilled holes. They are available in lengths from 1/4" to 3/4" / 6.35 to 19.05 mm in thread sizes #2-56 to 1/4-20 / M2 to M6. These inserts can be provided in aluminum, brass, steel and stainless steel.

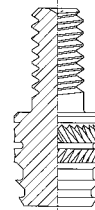

### SELF-LOCKING ULTRASONIC INSERTS

The self-locking feature prevents screw loosening and is advantageous in applications where vibration is present. They are available in thread sizes #2-56 to 1/4-20 / M2 to M6 and are designed for ultrasonic installation into straight or tapered holes.

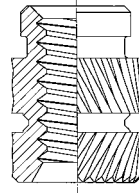

### THERMOPLASTIC INSERTS

Allows for mounting a component on the external thread. They are available in lengths from 3/16" to 1" / 4.76 to 25.4 mm. Thread sizes #4-40 to 1/4-20 / M3 to M6. SI thermoplastic inserts can be provided in aluminum, brass, steel and stainless steel and can be pressed into pre-molded or drilled holes.

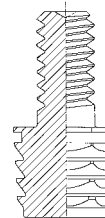

# HOLE PREPARATION GUIDELINES

As a general rule, the wall thickness should be 1/2 to 1 times the insert outside diameter. If the insert application is in a circular boss, the boss diameter should be 2 times the insert diameter. Thinner walls and bosses may be used but will affect performance.

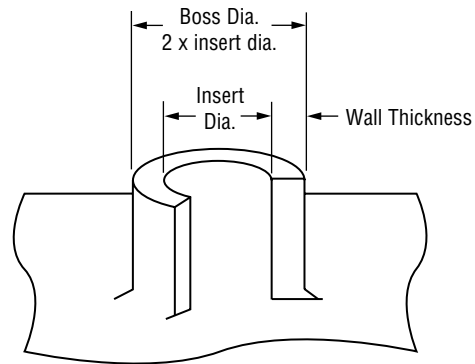

## PULLOUT

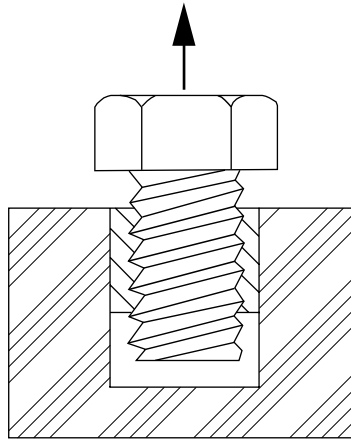

Pullout is the force required to pull the insert from the sheet.

## TORQUE OUT

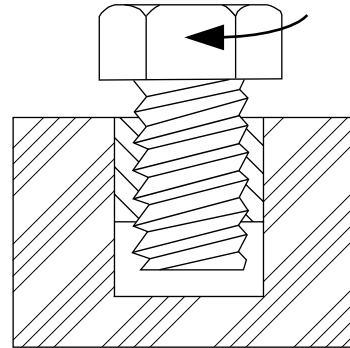

Torque-out is the torque required to turn the fastener in the parent material after installation without inducing clamp load on the fastener.

## SI® PROTOTYPE KIT



The SI prototype kit contains a wide variety of SI threaded inserts for plastics for your prototype needs. The kit contains over 1,000 ultrasonic, molded-in, and press-in inserts of various types and sizes, so you can choose the one which will best suit your specific design requirements. The kit contains both unified and metric parts.

PEM Part #PKSI-100. Price - US \$50.00 (Subject to change without notice).

*All specifications in this bulletin are presented as accurately and up-to-date as possible. We reserve the right to make changes to any information contained in this bulletin without notice.*

*We recommend that you test a particular product to be sure it is ideally suited to your application. We will be happy to provide samples for this purpose and our authorized distributors can also help you with your selection.*

RoHS compliance information can be found on our website.  
© 2012 PennEngineering.

Specifications subject to change without notice.  
See our website for the most current version of this bulletin.

**PennEngineering®**



**North America:** Danboro, PA USA • E-mail: [info@pemnet.com](mailto:info@pemnet.com) • Tel: +1-215-766-8853 • Fax: +1-215-766-0143 • 800-237-4736 (USA Only)  
**Europe:** Galway, Ireland • E-mail: [europe@pemnet.com](mailto:europe@pemnet.com) • Tel: +353-91-751714 • Fax: +353-91-753541  
**Asia/Pacific:** Singapore • E-mail: [singapore@pemnet.com](mailto:singapore@pemnet.com) • Tel: +65-6-745-0660 • Fax: +65-6-745-2400  
Shanghai, China • E-mail: [china@pemnet.com](mailto:china@pemnet.com) • Tel: +86-21-5868-3688 • Fax: +86-21-5868-3988

Visit our PEMNET™ Resource Center at [www.pemnet.com](http://www.pemnet.com)

Technical support e-mail: [techsupport@pemnet.com](mailto:techsupport@pemnet.com)