

PennEngineering®

CONCEALED-HEAD SELF-CLINCHING  
STUDS AND STANDOFFS



BULLETIN

CH



# CONCEALED-HEAD SELF-CLINCHING STUDS AND STANDOFFS

PEM® self-clinching concealed-head studs and standoffs install permanently in steel or aluminum sheets as thin as .062" / 1.6mm to provide strong and reusable threads for mating hardware in a wide range of thin-metal assembly applications. Their concealed-head feature contributes particular design benefits by allowing the side of the sheet opposite installation to remain smooth and untouched. This feature additionally serves to satisfy applications where the sheet must remain completely sealed from air, liquid, dust, gases, or other potentially infiltrating elements.

Sheet preparation for their installation requires only a blind milled hole to the recommended minimum depth. Using a PEMSERTER® or other standard press, installation is accomplished by placing the fastener in the hole and applying sufficient squeezing force. The fastener head then locks securely in the sheet and can handle substantial loads.

To meet national aerospace standards and to obtain testing documentation, Type CFHC studs can be ordered to NASM63540/4 specifications. Check our web site for a complete Military Specification and National Aerospace Standards Reference Guide (Bulletin NASM).

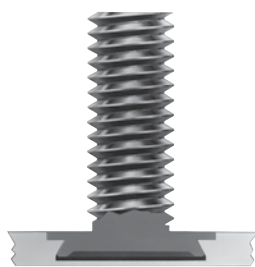

Concealed-head Stud

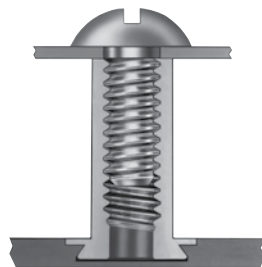

Concealed-head Standoff



Back side of sheet remains smooth



**Look for the PEM dimple trademark on studs and the PEM "two groove" trademark on standoffs.**



# CONCEALED-HEAD SELF-CLINCHING STUDS AND STANDOFFS

## ALUMINUM AND STAINLESS STEEL STUDS - TYPES CHA, CFHA, CHC AND CFHC

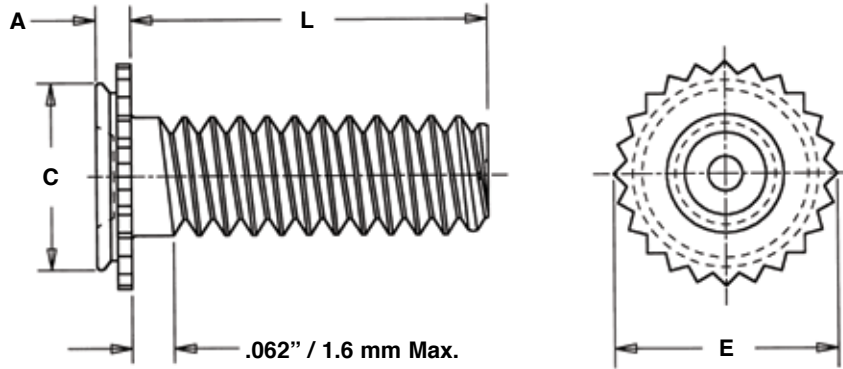

All dimensions are in inches.

UNIFIED	Thread Size	Type		Thread Code	Length Code "L" ±.015 (Length code is in 16ths of an inch)						Min. Sheet Thickness	Blind Mounting Hole Dia. +.003 -.000	Min. Depth of Blind Hole (1)	A Max.	E ±.010	C Max.	Min. Dist. Hole C To Edge	Max. Hole In Attached Parts
		Aluminum	Stainless Steel		.250	.375	.500	.625	.750	1.00								
	.112-40 (#4-40)	CHA CFHA	CHC CFHC	440	4	6	8	10	12	NA	.062 .093	.172	.043 .075	.041 .071	.205	.171	.156	.135
.138-32 (#6-32)	CHA CFHA	CHC CFHC	632	4	6	8	10	12	16	.062 .093	.213	.043 .075	.041 .071	.250	.212	.188	.160	
.164-32 (#8-32)	CHA CFHA	CHC CFHC	832	4	6	8	10	12	16	.062 .093	.290	.043 .075	.041 .071	.328	.289	.219	.185	
.190-32 (#10-32)	CHA CFHA	CHC CFHC	032	NA	6	8	10	12	16	.062 .093	.312	.043 .075	.041 .071	.350	.311	.250	.210	

All dimensions are in millimeters.

METRIC	Thread Size x Pitch	Type		Thread Code	Length Code "L" ±0.4 (Length code is in millimeters)						Min. Sheet Thickness	Blind Mounting Hole Dia. +0.08	Min. Depth of Blind Hole (1)	A Max.	E ±0.25	C Max.	Min. Dist. Hole C To Edge	Max. Hole In Attached Parts
		Aluminum	Stainless Steel		6	8	10	12	16	20								
	M3 x 0.5	CHA CFHA	CHC CFHC	M3	6	8	10	12	16	20	NA	1.6 2.4	4.37	1.1 1.91	1.04 1.8	5.21	4.35	4
M4 x 0.7	CHA CFHA	CHC CFHC	M4	6	8	10	12	16	20	25	1.6 2.4	7.37	1.1 1.91	1.04 1.8	8.33	7.35	5.6	4.6
M5 x 0.8	CHA CFHA	CHC CFHC	M5	NA	NA	10	12	16	20	25	1.6 2.4	7.93	1.1 1.91	1.04 1.8	8.89	7.9	6.4	5.6

(1) Blind holes may be deeper than minimums except where sheet material is at or near minimum thickness. Fasteners should always be installed so the flange is flush with the surface of the sheet.  
NA Not available.

### PART NUMBER DESIGNATION

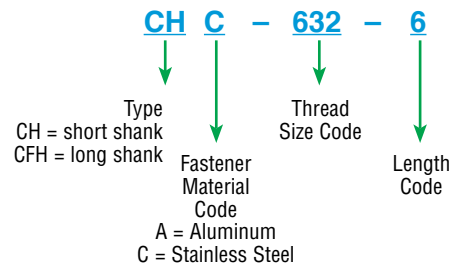

# CONCEALED-HEAD SELF-CLINCHING STUDS AND STANDOFFS

## STAINLESS STEEL STANDOFFS - TYPES CSS AND CSOS

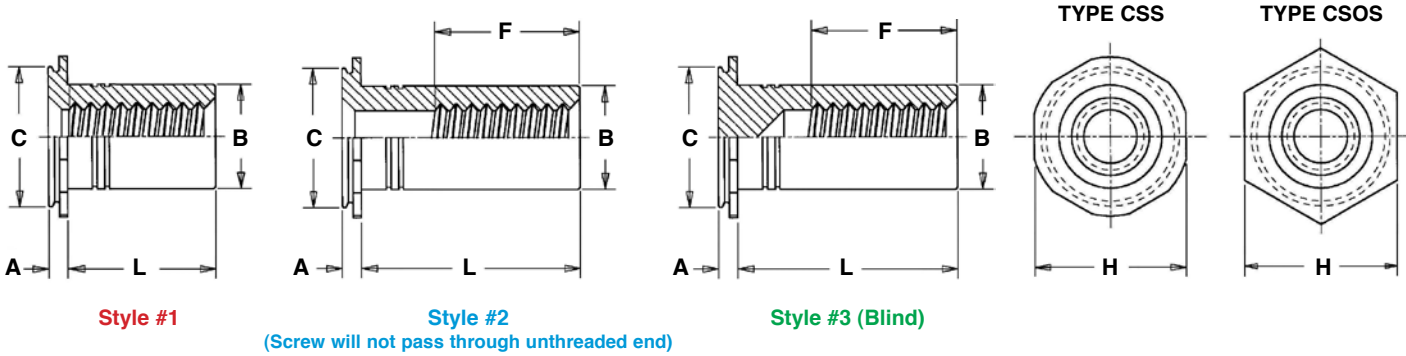

All dimensions are in inches.

UNIFIED	Thread Size	Type	Thread Code	Length Code "L" +.002 -.005 (Length code is in 16ths of an inch)							Min. Sheet Thickness	Blind Mounting Hole Dia. +.003 -.000	Min. Depth of Blind Hole (4)	Min. Depth Full Thread F	A Max.	B Max. (5)	C Max.	H Nom.	Min. Dist. Hole $\varnothing$ To Edge
		Stainless Steel		.187	.250	.312	.375	.500	.625	.750									
	.112-40 (#4-40)	CSS	440	3 <sup>(1)</sup>	4 <sup>(2)</sup>	5 <sup>(2)</sup>	6 <sup>(2)</sup>	8 <sup>(3)</sup>	10 <sup>(3)</sup>	12 <sup>(3)</sup>	16 <sup>(3)</sup>	.062	.213	.043	.188	.041	.165	.212	.250
CSOS		.093		.072	.072	.072	.072	.072	.072	.072	.072	.072	.072	.072	.072	.072	.072	.072	.072
.138-32 (#6-32)	CSS	632	3 <sup>(1)</sup>	4 <sup>(1)</sup>	5 <sup>(2)</sup>	6 <sup>(2)</sup>	8 <sup>(3)</sup>	10 <sup>(3)</sup>	12 <sup>(3)</sup>	16 <sup>(3)</sup>	.062	.290	.043	250	.041	.213	.289	.312	.219
	CSOS		.093	.072	.072	.072	.072	.072	.072	.072	.072	.072	.072	.072	.072	.072	.072	.072	.072
.164-32 (#8-32)	CSS	832	3 <sup>(1)</sup>	4 <sup>(1)</sup>	5 <sup>(2)</sup>	6 <sup>(2)</sup>	8 <sup>(3)</sup>	10 <sup>(3)</sup>	12 <sup>(3)</sup>	16 <sup>(3)</sup>	.062	.312	.043	.250	.041	.245	.311	.344	.250
	CSOS		.093	.072	.072	.072	.072	.072	.072	.072	.072	.072	.072	.072	.072	.072	.072	.072	.072
.190-32 (#10-32)	CSS	032	3 <sup>(1)</sup>	4 <sup>(1)</sup>	5 <sup>(1)</sup>	6 <sup>(1)</sup>	8 <sup>(2)</sup>	10 <sup>(3)</sup>	12 <sup>(3)</sup>	16 <sup>(3)</sup>	.062	.344	.043	.375	.041	.290	.343	.375	.281
	CSOS		.093	.072	.072	.072	.072	.072	.072	.072	.072	.072	.072	.072	.072	.072	.072	.072	.072
.250-20 (1/4-20)	CSS	0420	3 <sup>(1)</sup>	4 <sup>(1)</sup>	5 <sup>(1)</sup>	6 <sup>(1)</sup>	8 <sup>(2)</sup>	10 <sup>(2)</sup>	12 <sup>(3)</sup>	16 <sup>(3)</sup>	.062	.390	.043	.375	.041	.354	.389	.438	.375
	CSOS		.093	.072	.072	.072	.072	.072	.072	.072	.072	.072	.072	.072	.072	.072	.072	.072	.072

All dimensions are in millimeters.

METRIC	Thread Size x Pitch	Type	Thread Code	Length Code "L" +0.05 -0.13 (Length code is in millimeters)							Min. Sheet Thickness	Blind Mounting Hole Diameter +0.08	Min. Depth of Blind Hole (4)	Min. Depth Full Thread F	A Max.	B Max. (5)	C Max.	H Nom.	Min. Dist. Hole $\varnothing$ To Edge
		Stainless Steel		4 <sup>(1)</sup>	6 <sup>(1)</sup>	8 <sup>(2)</sup>	10 <sup>(3)</sup>	12 <sup>(3)</sup>	16 <sup>(3)</sup>	20 <sup>(3)</sup>									
	M3 x 0.5	CSS	M3	4 <sup>(1)</sup>	6 <sup>(1)</sup>	8 <sup>(2)</sup>	10 <sup>(3)</sup>	12 <sup>(3)</sup>	16 <sup>(3)</sup>	20 <sup>(3)</sup>	25 <sup>(3)</sup>	1.6	5.41	1.1	5	1.04	4.2	5.39	6.35
CSOS		2.4		1.91	1.91	1.91	1.91	1.91	1.91	1.91	1.91	1.91	1.91	1.91	1.91	1.91	1.91	1.91	1.91
M4 x 0.7	CSS	M4	4 <sup>(1)</sup>	6 <sup>(1)</sup>	8 <sup>(2)</sup>	10 <sup>(2)</sup>	12 <sup>(3)</sup>	16 <sup>(3)</sup>	20 <sup>(3)</sup>	25 <sup>(3)</sup>	1.6	7.92	1.1	6.5	1.04	6.23	7.9	8.74	6.4
	CSOS		2.4	1.91	1.91	1.91	1.91	1.91	1.91	1.91	1.91	1.91	1.91	1.91	1.91	1.91	1.91	1.91	1.91
M5 x 0.8	CSS	M5	4 <sup>(1)</sup>	6 <sup>(1)</sup>	8 <sup>(1)</sup>	10 <sup>(2)</sup>	12 <sup>(2)</sup>	16 <sup>(3)</sup>	20 <sup>(3)</sup>	25 <sup>(3)</sup>	1.6	8.74	1.1	9.6	1.04	7.37	8.72	9.53	7.2
	CSOS		2.4	1.91	1.91	1.91	1.91	1.91	1.91	1.91	1.91	1.91	1.91	1.91	1.91	1.91	1.91	1.91	1.91
M6 x 1	CSOS	M6	4 <sup>(1)</sup>	6 <sup>(1)</sup>	8 <sup>(1)</sup>	10 <sup>(2)</sup>	12 <sup>(2)</sup>	16 <sup>(3)</sup>	20 <sup>(3)</sup>	25 <sup>(3)</sup>	2.4	9.9	1.91	9.6	1.83	9	9.89	11.11	9.5

- (1) **Style #1.**
- (2) **Style #2.**
- (3) **Style #3.**
- (4) Blind mounting holes may be deeper than minimums except where sheet material is at or near minimum thickness. Fasteners should always be installed so the flange is flush with the surface of the sheet.
- (5) If standoff is used as a bushing, the hole in attached part must not exceed "B" plus .020" / 0.51 mm.

### PART NUMBER DESIGNATION

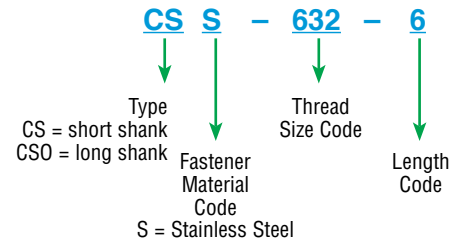

# CONCEALED-HEAD SELF-CLINCHING STUDS AND STANDOFFS

## PERFORMANCE DATA<sup>(1)</sup>

Type	Thread Code	Max. Tightening Torque Ref. (in. lbs.)	Test Sheet Material			
			Cold-rolled Steel		5052-H34 Aluminum	
			Installation (lbs.)	Pullout (lbs.)	Installation (lbs.)	Pullout (lbs.)
<b>UNIFIED</b>						
Concealed-head Standoffs						
CSS	440	4.75	4,000	300	2,800	200
	632	8.75	4,500	350	3,000	240
	832	18	4,800	400	4,000	270
	032	32	5,500	450	5,000	290
CSOS	440	3.8	4,300	330	2,900	220
	632	7	5,000	360	3,200	240
	832	14.4	5,300	440	4,000	300
	032	25.6	6,000	600	5,000	400
	0420	64	6,500	650	5,500	430
Concealed-head Studs						
CHC	440	4.75	1,800	240	1,400	130
	632	9	2,500	260	1,800	160
	832	18	4,000	270	2,800	180
	032	32	5,000	290	4,000	210
CFHC	440	4.75	2,000	240	1,500	200
	632	9	2,700	350	2,500	260
	832	18	3,300	440	3,000	310
	032	32	4,000	680	3,500	360
CHA	440	2.85	(2)	(2)	1,400	125
	632	5.4	(2)	(2)	1,800	135
	832	10.8	(2)	(2)	2,800	145
	032	19.2	(2)	(2)	4,000	170
CFHA	440	2.85	(2)	(2)	1,500	190
	632	5.4	(2)	(2)	2,500	220
	832	10.8	(2)	(2)	3,000	240
	032	19.2	(2)	(2)	3,500	300

Type	Thread Code	Max. Tightening Torque Ref. (N•m)	Test Sheet Material			
			Cold-rolled steel		5052-H34 Aluminum	
			Installation (kN)	Pullout (N)	Installation (kN)	Pullout (N)
<b>METRIC</b>						
Concealed-head Standoffs						
CSS	M3	.55	17.8	1330	12.5	890
	M4	2	21.3	1775	17.8	1200
	M5	3.6	24.5	2000	22.2	1290
CSOS	M3	.44	19.2	1465	12.9	975
	M4	1.6	23.6	1955	17.8	1335
	M5	2.9	26.7	2665	22.2	1775
	M6	7.2	28.9	2860	24.4	1915
Concealed-head Studs						
CHC	M3	0.5	8	1065	6.2	575
	M4	2	17.8	1200	12.5	800
	M5	3.6	22.2	1290	17.8	930
CFHC	M3	0.5	8.9	1065	6.7	890
	M4	2	14.7	1955	13.3	1375
	M5	3.6	17.8	3020	15.6	1600
CHA	M3	0.3	(2)	(2)	6.2	555
	M4	1.2	(2)	(2)	12.5	645
	M5	2.16	(2)	(2)	17.8	755
CFHA	M3	0.3	(2)	(2)	6.7	845
	M4	1.2	(2)	(2)	13.3	1065
	M5	2.16	(2)	(2)	15.6	1330

(1) The values reported are averages when all installation specifications and procedures are followed. Variations in mounting hole size, sheet material and installation procedure will affect results. Performance testing of this product in your application is recommended. We will be happy to provide samples for this purpose.

(2) Not recommended.

## MATERIAL AND FINISH SPECIFICATIONS

Type	Threads		Fastener Materials		Finish		For Use In Sheet Hardness (3)	
	External, ASME B1.1 2A / ASME B1.13M, 6g	Internal, ASME B1.1 2B / ASME B1.13M, 6H	Aluminum	300 Series Stainless Steel	No Finish	Passivated and/or tested per ASTM A380	HRB 70 / HB 125 or Less	HRB 50 / HB 89 or Less
CHA	•		•		•			•
CFHA	•		•		•			•
CHC	•			•		•	•	
CFHC	•			•		•	•	
CSS		•		•		•	•	
CSOS		•		•		•	•	

(3) HRB - Hardness Rockwell "B" Scale. HB - Hardness Brinell.



# CONCEALED-HEAD SELF-CLINCHING STUDS AND STANDOFFS

## INSTALLATION

1. Mill a blind hole to the correct minimum depth. Fasteners may also be installed into through holes.
2. Place fastener into anvil hole.
3. Place the sheet over the shank of the fastener.
4. With punch and anvil surfaces parallel, apply squeezing force until flange is flush with mounting sheet.

\*End mills available from PennEngineering. See chart below.

Types CFHA, CFHC, CHC, CHA  
Concealed-head studs

Types CSOS, CSS  
Concealed-head standoffs

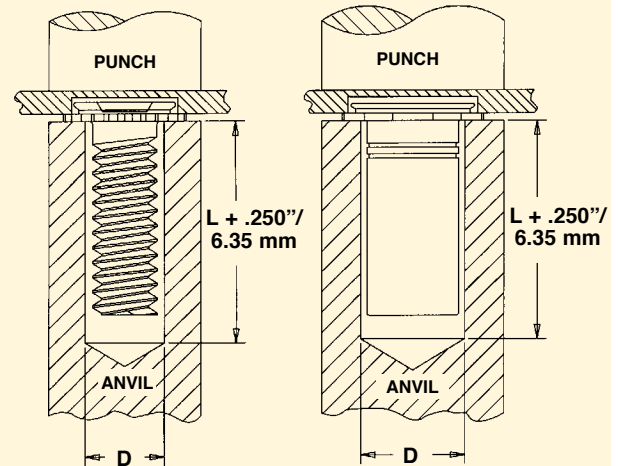

## ANVIL DIMENSIONS

All dimensions are in inches.

UNIFIED	Type	Thread Code	D +.003 - .000	Punch Part Number	Anvil Part Number
	CHA / CHC / CFHA / CFHC	440	.127	975200048	970200006300
	CHA / CHC / CFHA / CFHC	632	.152	975200048	970200007300
	CHA / CHC / CFHA / CFHC	832	.179	975200048	970200008300
	CHA / CHC / CFHA / CFHC	032	.205	975200048	970200009300
	CSS / CSOS	440	.170	975200048	970200014300
	CSS / CSOS	632	.218	975200048	970200015300
	CSS / CSOS	832	.250	975200048	970200016300
	CSS / CSOS	032	.295	975200048	970200017300
	CSS / CSOS	0420	.358	975200048	970200018300

All dimensions are in millimeters.

METRIC	Type	Thread Code	D +0.08	Punch Part Number	Anvil Part Number
	CHA / CHC / CFHA / CFHC	M3	3.4	975200048	970200229300
	CHA / CHC / CFHA / CFHC	M4	4.4	975200048	970200019300
	CHA / CHC / CFHA / CFHC	M5	5.4	975200048	970200020300
	CSS / CSOS	M3	4.33	975200048	970200014300
	CSS / CSOS	M4	6.36	975200048	970200016300
	CSS / CSOS	M5	7.5	975200048	970200017300
	CSS / CSOS	M6	9.13	975200048	970200018300

## END MILL INFORMATION

Double-ended, two-flute H.S.S. center-cutting end mills are available from stock.

PennEngineering does not manufacture center-cutting end mills, but we do keep a supply in stock for your convenience.

Thread Code	Fastener Type	Required Size End Mill	PEM Part No.
440, M3	CFHC, CHC, CFHA, CHA Studs	.172"	CHM-172
	CSOS, CSS Standoffs	.213"	CHM-213
632	CFHC, CHC, CFHA, CHA Studs	.213"	CHM-213
	CSOS, CSS Standoffs	.290"	CHM-290
832, M4	CFHC, CHC, CFHA, CHA Studs	.290"	CHM-290
	CSOS, CSS Standoffs	.312"	CHM-312
032, M5	CFHC, CHC, CFHA, CHA Studs	.312"	CHM-312
	CSOS, CSS Standoffs	.344"	CHM-344
0420, M6	CSOS Standoffs	.390"	CHM-390

RoHS compliance information can be found on our website.  
© 2012 PennEngineering.

Specifications subject to change without notice.  
See our website for the most current version of this bulletin.

**PennEngineering®**



**North America:** Danboro, PA USA • E-mail: info@pemnet.com • Tel: +1-215-766-8853 • Fax: +1-215-766-0143 • 800-237-4736 (USA Only)  
**Europe:** Galway, Ireland • E-mail: europe@pemnet.com • Tel: +353-91-751714 • Fax: +353-91-753541  
**Asia/Pacific:** Singapore • E-mail: singapore@pemnet.com • Tel: +65-6-745-0660 • Fax: +65-6-745-2400  
 Shanghai, China • E-mail: china@pemnet.com • Tel: +86-21-5868-3688 • Fax: +86-21-5868-3988

Visit our PEMNET™ Resource Center at [www.pemnet.com](http://www.pemnet.com)

Technical support e-mail: [techsupport@pemnet.com](mailto:techsupport@pemnet.com)